

INSTRUCTION MANUAL

Semi-electric Stacker

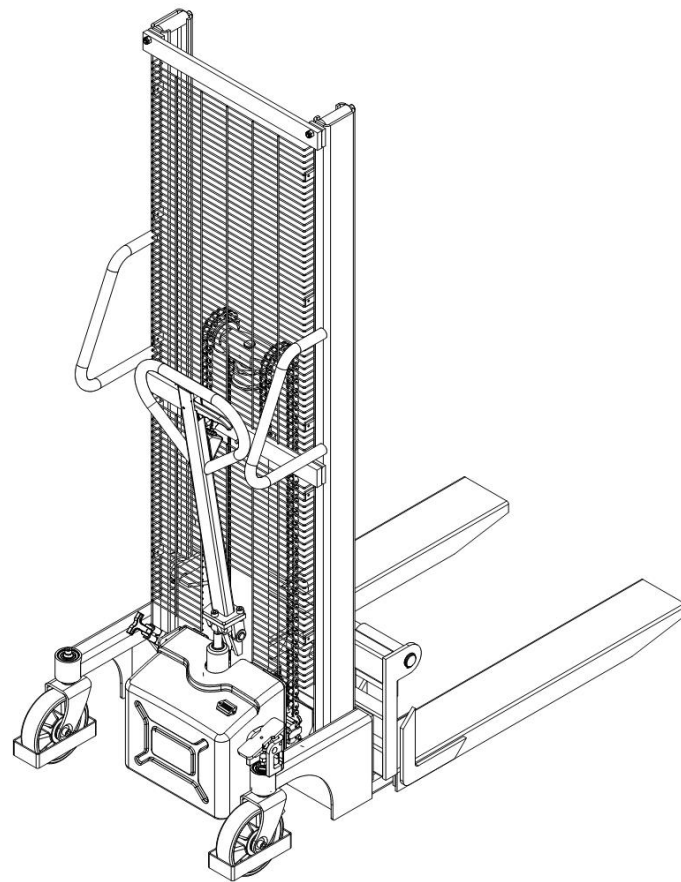

WARNING

Do not use the electric truck before reading and understanding these operating instructions.



NOTE:

- Please check the stickers of your present type on the truck.
- Keep for future reference.

Version 06/2021

ESFH10-SMS-001-EN

Introduction

Welcome to use this series of power stackers. This manual gives clear information on how to master safe operation of the power stackers.

The differences between various power stackers are described in detail in this manual. During operation and maintenance, please refer to the contents corresponding to the type of the power stacker you are using.

The safety instructions and important precautions are indicated with the following icons:



1.  ---- This icon indicates the existence of a hazard that could result in personal injury if the safety instruction is not observed.



2.  ---- This icon indicates that a failure to observe the described instruction could lead to equipment damage



3.  ---- Refers to general notes and instructions before use.



Most parts of the product are made from recyclable steel. The recycling and disposal of cast-offs resulted during using, maintenance, cleaning and disassembling the product has to comply with local regulations without pollution to the environment. The recycling and disposal of the cast-offs should only be operated by specialised personnel in the designated area. The cast-offs such as hydraulic oil, batteries and electronic units, if improperly disposed, may be hazardous to the environment and human health.



Due to continuous product improvement, Noblelift reserves the right to make changes in product designs and specifications without prior notice. For the latest product parameters, please feel free to contact us. Note: All parameters provided herein are as of the publication date of the Instruction Manual.

Catalogue

1.	CORRECT APPLICATION	3
2.	DESCRIPTION OF THE STACKER	4
	a. Overview of the main components	4
	b. Main technical data	5
	c. Description of the safety devices and warning stickers.....	6
	d. Identification plate	7
3.	WARNINGS, RESIDUAL RISK AND SAFETY INSTRUCTIONS	7
4.	COMMISSIONING, TRANSPORTING, DECOMMISSIONING	8
	a. Commissioning	8
	b. Hoisting/ transportation.....	8
	c. Decommissioning	9
5.	DAILY INSPECTION	9
6.	OPERATING INSTRUCTIONS	10
	a. Parking.....	10
	b. Residual capacity diagram.....	10
	c. Lifting.....	10
	d. Lowering	10
	e. Malfunctions.....	10
	f. Emergency.....	11
7.	BATTERY CHARGING AND REPLACEMENT	11
	a. Charging	11
	b. Replacement.....	11
	c. Battery disposal	11
8.	REGULAR MAINTENANCE	11
	a. Daily maintenance	12
	b. Lubricating points.....	12
	c. Check and refill hydraulic oil.....	12
	d. Remove and reattach the protection guard	12
9.	TROUBLE SHOOTING	13
10.	WIRING/ CIRCUIT DIAGRAM	15
	a. Electrical circuit diagram.....	15
	b. Wiring diagram.....	16
11.	HYDRAULI CIRCUIT	17

1. CORRECT APPLICATION

It is only allowed to use this electric stacker according to this instruction handbook.

The trucks described in this handbook are self propelled pedestrian controlled electric power stacker with electrically powered low height lifting function. The trucks are designed for stacking operations in dedicated racking by lifting and lowering the palletized load up to the desired lifting height.

A wrong usage can cause human injuries or can damage equipment.

The operator/ the operating company has to ensure the correct usage and has to ensure, that this truck is used only by staff, which is trained and authorized to use this truck.

The truck has to be used on substantially firm, smooth, prepared, level and adequate surfaces. The truck is intended to be used for indoor applications with ambient temperatures between +5°C and + 40°C and for light duty applications without crossing permanent obstacles or potholes. Operating on ramps is not allowed. While operating, the load must be placed approximately on the longitudinal centre plane of the stacker.

Lifting or transporting people is forbidden. If travelling the load must be lowered to the lifting point.

It is not allowed to use this truck on tail lifts or loading ramps.

The capacity is marked on the load diagram as well on the Identification plate. The operator has to consider the warnings and safety instructions.

Operating lighting must be minimum 50 Lux.

Modification

No modifications or alterations to this truck which may affect, for example, capacity, stability or safety requirements of the truck, shall be made without the prior written approval of the original truck manufacturer, its authorized representative, or a successor thereof. This includes changes affecting, for example braking, steering, visibility and the addition of removable attachments. When the manufacturer or its successor approve a modification or alteration, they shall also make and approve appropriate changes to capacity plate, decals, tags and operation and maintenance handbooks.

By not observing these instructions, the warranty becomes void.

2. DESCRIPTION OF THE STACKER

a. Overview of the main components

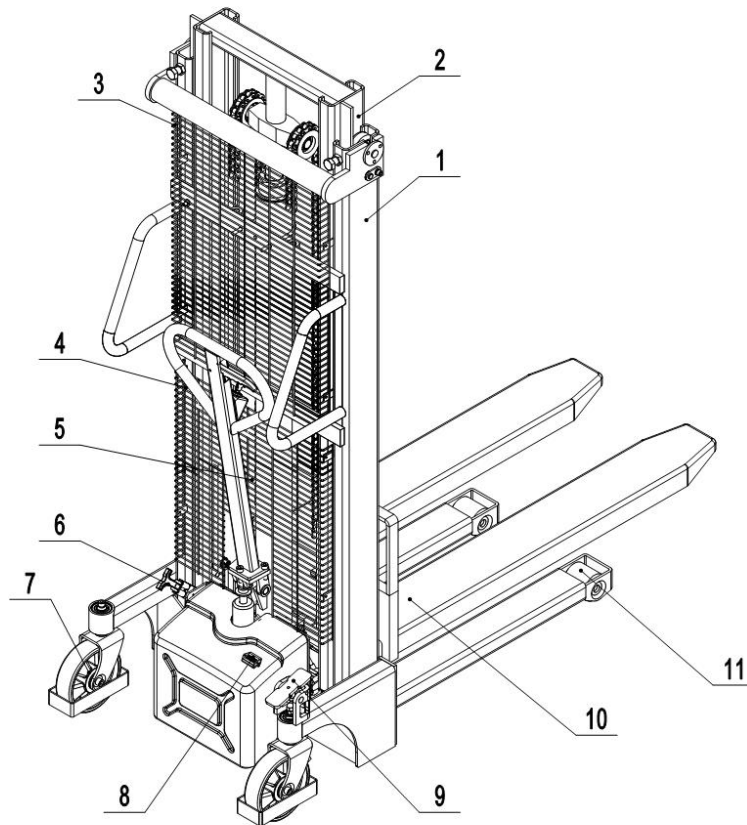

Fig. 1: Overview main components

- | | |
|---------------------|----------------------|
| 1. Outer mast | 7. Wheel |
| 2. Inner mast | 8. Battery indicator |
| 3. Protective cover | 9. Brake |
| 4. Handle | 10. Fork |
| 5. Cylinder | 11. Load roller |
| 6. Power connector | |

b. Main technical data

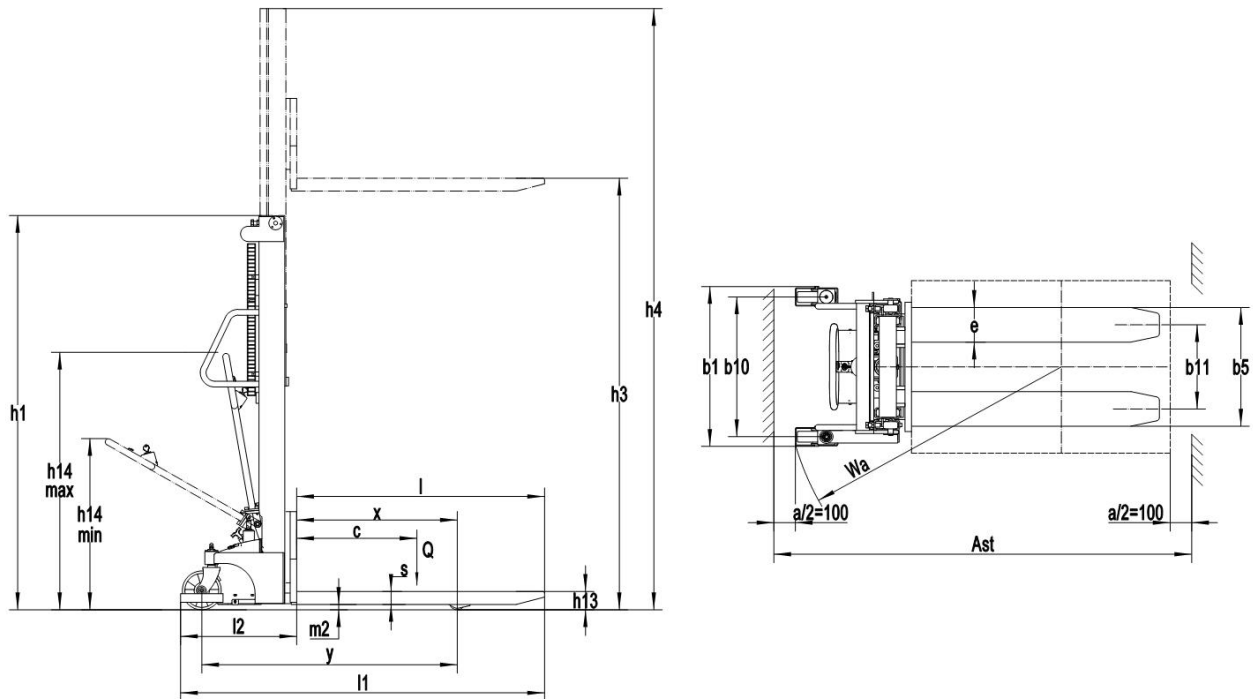

Fig. 2: Technical data

Table1: Main technical data for standard version

Type sheet for industrial truck acc. to VDI 2198					
Distinguishing mark	1.2	Manufacturer's type designation		ESFH1016	ESFH1025
	1.3	Power (battery ,diesel, petrol, gas, manual)		Manual	
	1.4	Operator type		Pedestrian	
	1.5	Load Capacity / rated load	Q(t)	1.0	0.8
	1.6	Load centre distance	c(mm)	600	
	1.8	Load distance ,centre of drive axle to fork	x(mm)	760/(645) ¹⁾	745/(640) ¹⁾
	1.9	Wheelbase	Y(mm)	1205/(1150) ¹⁾	1185/(1150) ¹⁾
Weight	2.1	Service weight	kg	250	330
	2.2	Axle loading, laden front/rear	kg	326/924	370/960
	2.3	Axle loading, unladen front/rear	kg	155/95	230/100
Tires, chassis	3.1	Tires		Polyurethane	
	3.2	Tire size, front	∅ x w (mm)	Φ180x50	
	3.3	Tire size, rear	∅ x w (mm)	Φ74x70	
	3.4	Additional wheels(dimensions)	∅ x w (mm)	Φ180x50	
	3.5	Wheels, number front/rear(x=driven wheels)		2/2	
	3.6	Track, front	b10 (mm)	648	
	3.7	Track, rear	b11 (mm)	390(590) ¹⁾	
Dimensions	4.2	Lowered mast height	h1 (mm)	1983	1828
	4.3	Free Lift height	h2 (mm)	1515	/
	4.4	Lift height	h3 (mm)	1515	2415

	4.5	Extended mast height	h4 (mm)	1983	3037
	4.9	Height of tiller in drive position min./ max.	h14 (mm)	815/1175	
	4.15	Height, lowered	h13 (mm)	85	
	4.19	Overall length	l1 (mm)	1690/(1510) ¹⁾	
	4.20	Length to face of forks	l2 (mm)	540/(610) ¹⁾	
	4.21	Overall width	b1 (mm)	740	
	4.22	Fork dimensions	s/e/l (mm)	60/160/1150/(60/170/900) ^{1) 2)}	
	4.25	Distance between fork-arms	b5 (mm)	550/(330~740) ¹⁾	
	4.32	Ground clearance, centre of wheelbase	m2 (mm)	25	
	4.33	Aisle width for pallets 1000X1200 crossways	Ast (mm)	2160	
	4.34	Aisle width for pallets 800X1200 lengthways	Ast (mm)	2130	
	4.35	Turning radius	Wa (mm)	1285	
Performance data	5.2	Lift speed, laden/ unladen	m/s	0.05/0.06	
	5.3	Lowering speed, laden/ unladen	m/s	0.16/0.14	
	5.10	Service brake		Manual	
Electric-engine	6.2	Lift motor rating at S3 10%	kW	1.2	
	6.3	Battery acc. to DIN 43531/35/36 A, B, C, no		no	
	6.4	Battery voltage, nominal capacity K5	V/Ah	48V/20Ah	
	6.5	Battery weight	kg	27	

1).The data in brackets is for ESFH10 with adjustable width of forks ; 2). Options of adjustable forks: 1100mm, 1150mm

c. Description of the safety devices and warning stickers

- 1 Crane hook decal
- 2 Capacity label
- 3 Warning decal (do not stand under/on the forks)
- 4 Residual capacity label
- 5 Identification plate (ID plate)
- 6 Warning sticker
- 7 Sticker (operation instructions)

The stacker has a power connector (6) which stops all lifting-, lowering-, driving- functions and engages the fail-safe electromagnetic brake when it is disconnected. Before operating, insert the key and turn the key switch (13) clockwise. To prevent unauthorized access, turn the key counterclockwise and remove it if you do not operate this stacker. Follow all the instructions given on the labels and decals. Replace the labels and decals if they are damaged or missing.

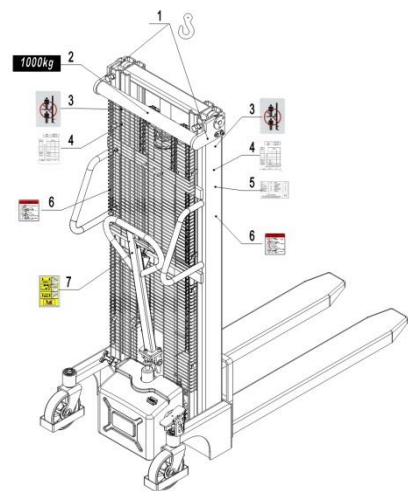

Fig.3: Safety and warning stickers

d. Identification plate

Type	xxx	Option	xxx
Serial No.	xxx	Year of Manuf.	xxx
Rated capacity	xxx	Load distance center	xxx
System voltage	xxx	Nominal power	xxx
Net weight without battery	xxx	Battery min/max mass	xxx
Noblelift Intelligent Equipment Co., Ltd. No. 528 Chang Zhou Road, Taihu Sub-district, Changxing county, Zhejiang province, China			

Fig. 4: Identification plate

3. WARNINGS, RESIDUAL RISK AND SAFETY INSTRUCTIONS



DO NOT

- Lift the load higher than the lifting point if you operate the truck outdoors.
- Put foot or hand under or into the lifting mechanism.
- Allow other person than the operator to stand in front of or behind the truck when it is moving or lifting/lowering.
- Overload the truck.
- Put foot in front of the wheels, injury could result.
- Lift people. People could fall down and suffer severe injury.
- Push or pull loads.
- Use this truck on ramps.
- Use the truck without protective cover (Fig.1,3)
- Side or end load. Load must be distributed evenly on the forks.
- Use the truck with unstable, unbalanced not stable load.
- Use truck without manufacturer's instructions manual.
- Lifted loads could become unstable at wind forces. In the case of wind forces do not lift the load if there is any influence to the stability.

Watch difference in floor levels when driving. Load could fall down or the truck could get uncontrollable. Keep watching the condition of load. Stop operating the truck if load becomes unstable. Brake the truck immediately and disconnect the power connector (6) when sliding load on/off the truck. If the truck has any malfunctions, follow chapter 6.

Do maintenance work according to regular inspection. This truck is not designed to be water resistant.

Use the truck under dry condition. Long and continuous operation might cause damage to the battery. Stop operation if temperature of hydraulic oil is too high.



- When operating the truck, the operator has to wear safety shoes.
- The truck is intended to be used for indoor applications with ambient temperature between +5°C and + 40°C.
- The operating light must be minimum 50 Lux.
- It is not allowed to use the truck on ramps.
- To prevent unintended sudden movements (i.e. caused by another person, etc.) when you are not operating the truck, switch off the truck and remove the key.

4. COMMISSIONING, TRANSPORTING, DECOMMISSIONING

a. Commissioning

Table 2: Commissioning data

Type	ESFH10(1600)	ESFH10(2500)
Commissioning weight [kg]	1000	1000
Lift height [mm]	1600	2500

After receiving our new truck or for re-commissioning you have to do following before (firstly) operating the truck:

- Check if all parts are included and not damaged.
- Eventually installation and charging the batteries (see chapter 7).
- Do daily inspections as well as functional checks.

b. Hoisting/ transportation

For transporting, remove the load, lower the forks to the lowest position and fix the truck safely with dedicated hoisting equipment.

Hoisting



**USE DEDICATED CRANE AND HOISITING EQUIPMENT
DO NOT STAND UNDER THE SWAYING LOAD
DO NOT WALK INTO THE HAZARDOUS AREA DURING HOISITING**

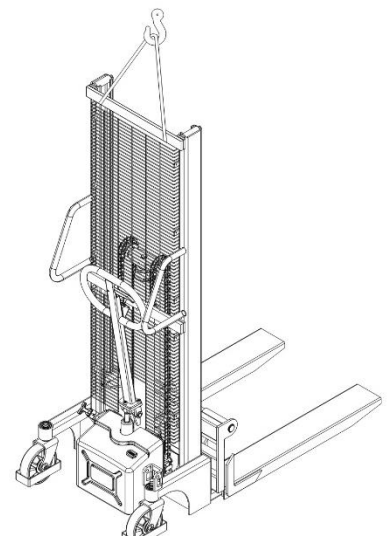

Fig.5: Hoisting with a crane

Park the truck securely and lash the truck according to the points identified in fig. 5

Move the truck to the destination and place the truck securely before removing the hoisting equipment.

Transportation



DURING TRANSPORTATION ON A LORRY OR TRUCK ALWAYS FASTEN THE STACKER SECURELY

Lower the forks and park the truck securely.

Fasten the truck according to fig.6 by fixing dedicated lashing belts to each side of the truck's crane hook holes and fasten the other side at the transporting vehicle.

c. Decommissioning

For storage, remove the load, lower the truck to the lowest position, grease all grease points required in this manual (regular inspection) To protect the truck against corrosion and dust. Remove batteries and check the safety of the truck to avoid flattening after storage. For final decommissioning, send the truck to a designated recycling company. Oil, batteries and electric components must be recycled due to legal regulations.

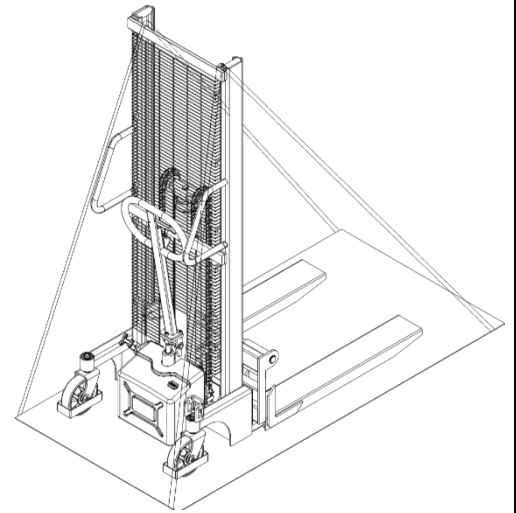

Fig. 6: Fixing points

5. DAILY INSPECTION

This chapter describes the checks before putting the truck into operation.

Daily inspection is effective to find the malfunctions or faults on this truck. Check the following points before operation.



DO NOT USE THE TRUCK IF ANY MALFUNCTION IS FOUND.

- Check for scratches, deformation or cracks.
- Check if there is any oil leakage from the cylinder.
- Check the chain and rollers for damages or corrosion.
- Check the smooth movement of the wheels.
- Check if the power connector is well connected.
- Check the lifting and lowering functions by operating the buttons.
- Check the protective cover for damages and wrong assembling.
- Check if all bolts and nuts are tightened firmly.
- Check the function of the key switch.
- Visual check if there are any broken hoses or electric wires.

6. OPERATING INSTRUCTIONS

BEFORE OPERATING THIS TRUCK, PLEASE FOLLOW THE WARNINGS AND SAFETY INSTRUCTIONS (SEE CHAPTER 3).

BEFORE OPERATING THIS TRUCK, ENSURE THAT THE LOAD OR OTHER EQUIPMENT WILL NOT CAUSE INSUFFICIENT VISIBILITY!

a. Parking



DO NOT PARK THE TRUCK ON INCLINED SURFACES

Always fully lower the forks and drive the truck to a safe area. Turn the key counterclockwise to "Off" position and remove the key.

b. Residual capacity diagram

The residual capacity diagram indicates the maximum capacity Q [kg] for a given load centre c [mm] and the corresponding lift height H [mm] for the truck with horizontal load.

For instance with a load centre of gravity distance c of 600 mm and a maximum lift height H of 2500 mm, the max. capacity Q is 800 kg.

c. Lifting



DO NOT OVERLOAD THE TRUCK!

THE MAXIMUM CAPACITY IS 1000 kg.

LIFT ONLY CAPACITIES ACCORDING TO THE RESIDUAL LIFT DIAGRAM.

Control the oil pump handle until the pallet reached the desired lifting height.

d. Lowering

Control the oil pump handle until the forks are clear of the pallet, then drive the truck carefully out of the load unit.

e. Malfunctions

If there are any malfunctions or the truck is inoperative, please stop using the truck and disconnect the power connector (6). If possible, park the truck on a safe area, turn the key switch (13) counterclockwise and remove the key.

Inform immediately the manager and, or call your service. If necessary, tow the truck out of the operating area by using dedicated towing/ hoisting equipment.

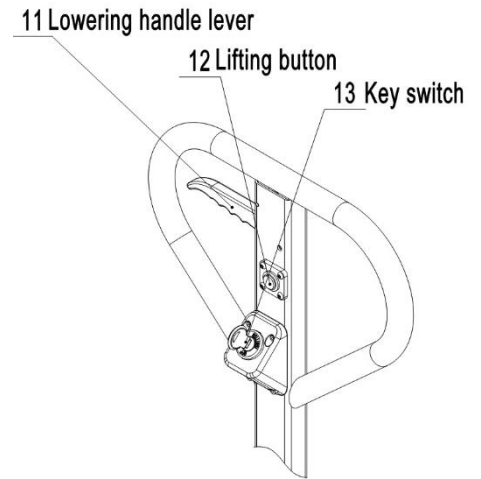

Fig.7: Control Handle

Type	ESFH10
Mast	2500 mm

h3 (mm)	Q (kg)	
2500	800	
2000	1000	
1600	1000	
c(mm)	600	

Fig. 8: Residual capacity diagram

f. Emergency

In emergencies or in the event of tip over (or off dock), keep safe distance immediately. Disconnect the power connector (6) if possible. All electrical functions will be stopped.

7. BATTERY CHARGING AND REPLACEMENT

Only qualified personnel are allowed to do service or charge the batteries. The instructions of this manual, refilling preparation and charging requirements must be understood. The truck is equipped with lead-acid batteries: 12V/20Ah.

a. Charging



- When battery indicator is flashing, charge the battery.
- It is not allowed to use the battery during charging.
- Charge the battery by the appropriate charger equipped with the truck.
- Before using the charger, please fully understand the instructions for charger.
- Always follow these instructions!
- The area for charging must be ventilated and away from the flame or spark.

b. Replacement

Park the truck securely and switch off the stacker through the key switch (6). Remove the screw on the electrical main cover and remove the cover. Remove the cable that connect the battery electrodes, then remove the battery hoop and take out the battery. The installation is in the reverse order of the removal.

c. Battery disposal

Waste batteries must be properly disposed and recycled according to the national regulations and if necessary brought the batteries to a qualified recycling company.

8. REGULAR MAINTENANCE



- Only qualified and trained personnel are allowed to do maintenance on this truck.
- Before maintaining, remove the load and lower the forks to the lowest position.
- If you need to lift the truck, follow chapter 4 by using designated lashing or jacking equipment. Before working, put safety devices (for instance designated lift jacks, wedges or wooden blocks) under the truck to protect against accidental lowering, movement or slipping.
- Please pay attention to the maintenance of the tiller arm. The gas spring is assembled by compression. Carelessness can cause injury.
- Please use approved and from your dealer released original spare parts.
- Please consider that leakage of hydraulic oil can cause failures and accidents.

a. Daily maintenance

In order to keep the truck well, it's necessary to inspect and maintain the truck everyday. (1) Clean the wheel and the spindle (2) Check if the fork and the mast are deformed; (3) Check if the battery voltage is normal. Remove the load from the forks and lower the forks to the lowest position after use.

b. Lubricating points

Lubricate the marked points according to Fig. 9. The required grease specification is: DIN 51825, standard grease.

- 1 Mast chain
- 2 Roller bearing
- 3 Load roller bearing
- 4 Steering wheel bearing

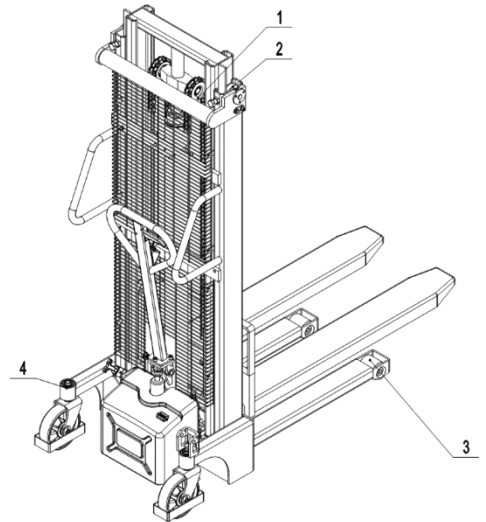

Fig. 9: Lubricating points

c. Check and refill hydraulic oil

It is recommended to use hydraulic oil in connection with average temperature:

Environment temperature	-5°C~25°C	>25°C
Type	HVLP 32, DIN 51524	HLP 46, DIN 51524
Viscosity	28.8-35.2	41.4 - 47
Amount	2.5L	

Check the oil level every 6 months. Waste material like oil must be properly disposed and recycled according to the national regulations and if necessary brought to a recycling company.

Waste material like oil, used batteries or other must be properly disposed and recycled according to the national regulations and if necessary brought to a recycling company.

d. Remove and reattach the protection guard



DO NOT USE THIS TRUCK, IF THE GUARD IS DAMAGED OR NOT CORRECTLY ASSEMBLED!

If the protection cover needs to be removed, remove the fixing screws and the guard screen carefully. For reattaching, place the screen to the right position and fix each screw correctly. If you need to replace parts, please call the after-sales service.

9. TROUBLE SHOOTING



- If the truck has malfunctions, follow the instructions of chapter 6.

Table 3: Trouble shooting

No.	TROUBLE	CAUSE	REPAIR
1	Forks can not reach the maximum lifting	Insufficient hydraulic oil.	Refill the hydraulic oil.
2	Load cannot be lifted	No hydraulic oil.	Refill the hydraulic oil.
		Hydraulic oil is not pure.	Change the hydraulic oil.
3	Pump motor doesn't work	Key switch is not activated.	Turn the key switch clockwise.
		Power connector is not well-connected.	Connect the power connector well.
		Battery is low.	Charge the battery.
		Power cord is not well-connected.	Tighten the connecting part.
		Motor contactor is damaged.	Replace the contactor.
4	Forks cannot be lowered	The piston rod or the cylinder body is deformed due to the cargo leaning to one side or the truck being overloaded.	Replace the piston rod or cylinder.
		The forks are kept at a high position for a long time, causing the piston rod exposed long time and rusted, which blocks the movement of the piston rod.	Lower the forks to the lowest position when not in use, and pay attention to timely lubricate the piston rod.
		The lowering adjustment screw is loose and cannot be lowered.	Tighten the lowering adjustment screw.
5	Oil leakage	The seal is aged or damaged.	Replace with new seal.
		Some parts are broken.	Replace with new part.
6	Forks drop	The impure hydraulic oil causes the release valve to not close tightly.	Replace hydraulic oil.
		The seal is aged or damaged.	Replace the seal.
		The relief valve is damaged.	Replace the valve.
7	Battery cannot be charged	Battery is damaged.	Replace the battery.

		Power connector is not well-connected.	Connect the power connector well.
--	--	--	-----------------------------------

10. WIRING/ CIRCUIT DIAGRAM

a. Electrical circuit diagram

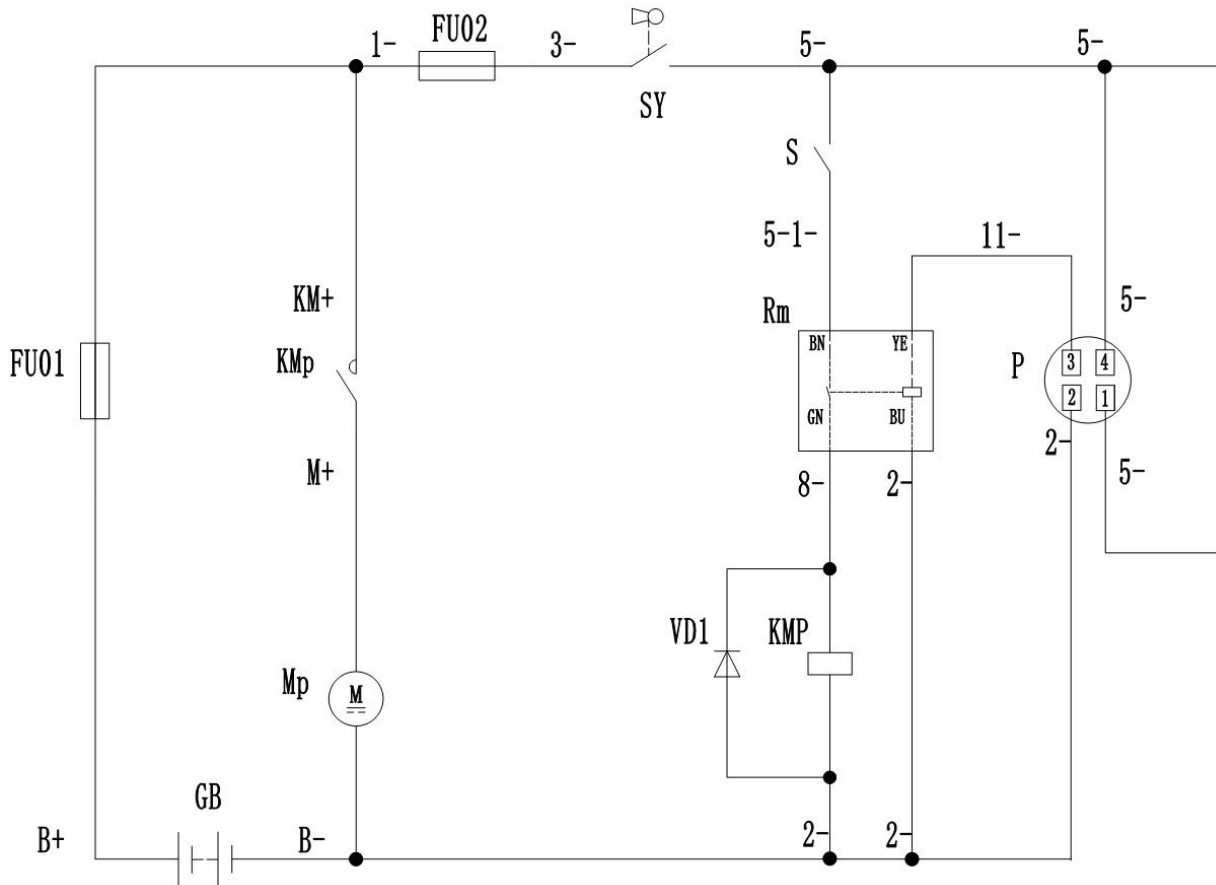
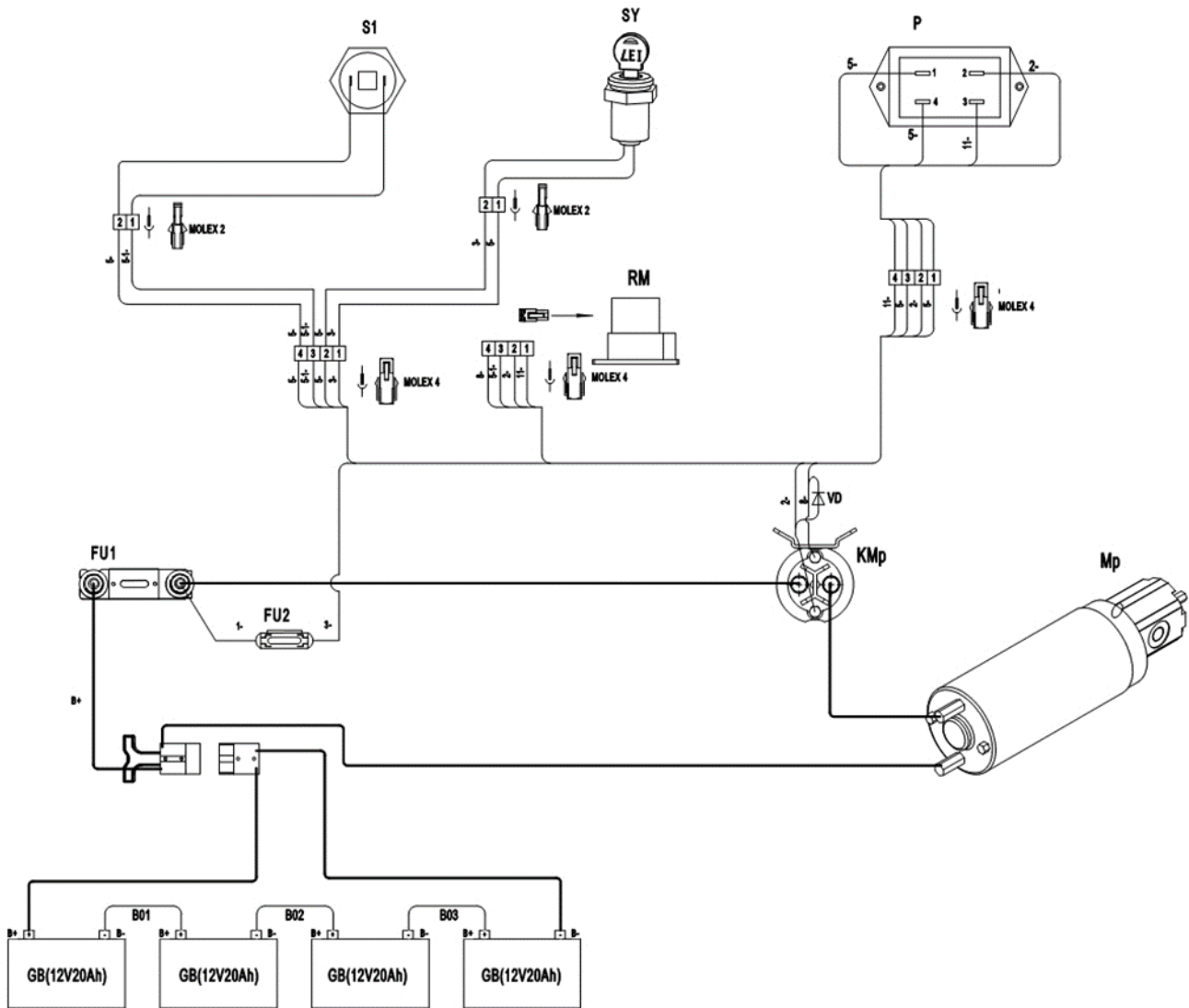

Fig. 10: Electric diagram

b. Wiring diagram



11. HYDRAULI CIRCUIT

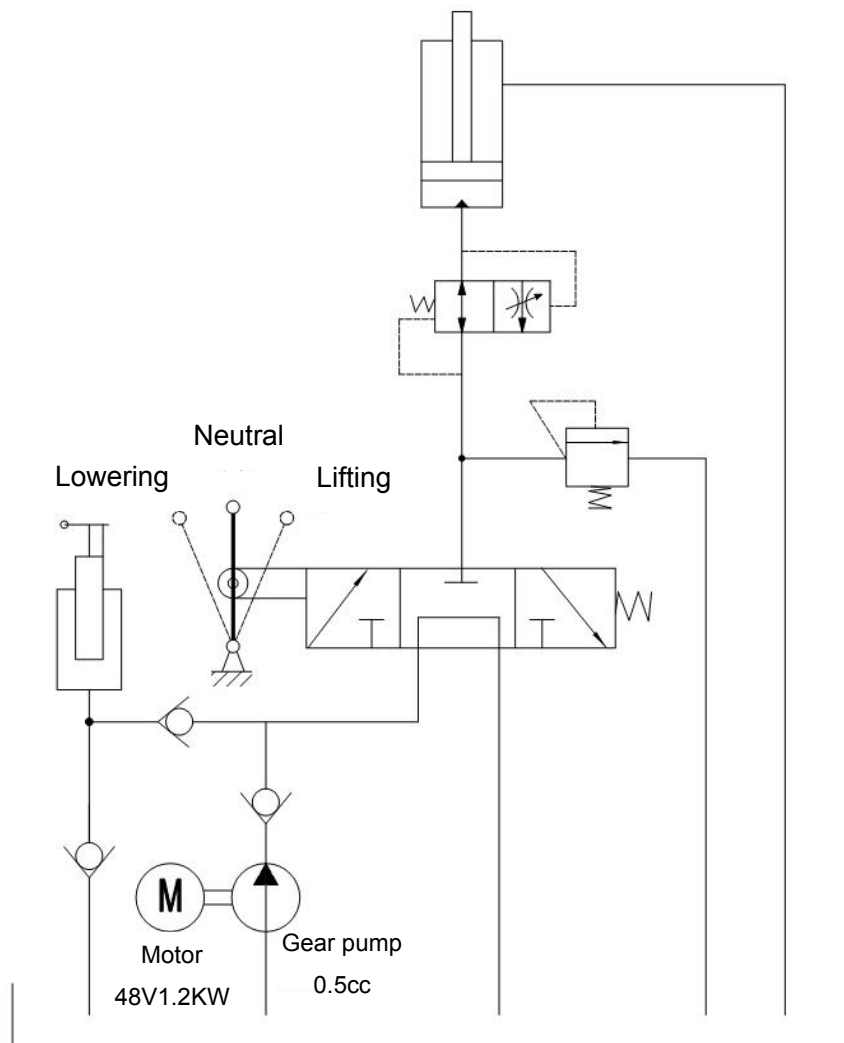

Fig. 12: Hydraulic diagram