

# PT20/25P-C

Ideal selection for heavy-duty and long-distance transportation operations with a fixed or foldable platform and floating drive wheel with high traveling speed, especially for logistics companies.

The fixed platform with roomy, safe, and ergonomic design is the first choice for intralogistics transportation over long distances; the foldable platform saves space in narrow aisles.

## ADVANTAGES

- Powerful high-quality AC drive unit.
- EPS-Electric Power Steering.
- Side battery exchange design makes battery replacement more convenient and safe.
- Robust and ergonomic design.
- American Curtis controller.
- REMA tiller.
- Fixed platform or foldable platform with guard rail.



Foldable platform

Fixed platform



# PT20/25P-C Electric pallet truck

The medium speed truck designed for logistics companies

## Noblelift Headquarters

Add:#528 Changzhou Road, Taihu  
Sub-district, Changxing, 313100, China  
TEL:+86 572 6210311/6120989  
FAX:+86 572 6129336  
WEB:www.noblelift.com  
Email: info@noblelift.com



Official website



Our Wechat

## Noblelift North America Corp.

Add:2461 S Wolf Road, Des Plaines, IL 60018  
Tel:847-595-7100  
Fax:847-595-7200  
Email:sales@nobleliftna.com  
Http: www.nobleliftna.com

## Noblelift Europe GmbH

Add:Borsigstrasse 9d-93092 Barbing  
Germany  
TEL:+49 9401 607930  
FAX:+49 9401 6079329  
WEB:www.noblelifteuopr.com  
Email: mail@noblelifteurope.com

## Noblelift Russia

ООО "Ноблелифт Рус"  
194292, Санкт-Петербург  
Домостроительная ул. 4А офис 301  
Бизнес-центр "Парнас"  
тел.: +7 (800) 700 - 28-97  
Email: sales@noblelift.com.ru

NOBLELIFT INTELLIGENT EQUIPMENT CO., LTD

www.noblelift.com

NEW *Noblelift Products*  
ARRIVAL



# PT20/25P-C



## Highlights



### German REMA Ergonomic tiller and handle

Ergonomic handle, easy to use on both sides. The chronic switch ensures safer operation in narrow spaces.

### High performance

The electric power steering system makes operation more efficient and effortless.

### AC drive technology

A powerful high-quality floating AC drive unit ensures high performance, low maintenance, and long service life of the truck. Adjustable pressure drive, unloaded speed 9.0km/h, 2T full-load speed 7km/h, 2.5T full-load speed 6.5km/h. Its floating drive and 1.6KW high power make it has low requirements for road smoothness.



### Control elements

Key-switch, emergency switch, and battery discharge indicator.



### Controller

American Curtis controller.



### Sideways battery exchange

Sideways battery exchange compartment for quick and safe battery exchange. Because the battery compartment is lifted with forks, various exchange heights are easy to reach.



### Powerful battery

High-performance German DIN standard battery for long or multi-shift operation. The battery rollers minimize the forces needed for exchange. Optional 180Ah, 210Ah, and 270Ah lead-acid batteries, also the largest 315Ah lead-acid batteries. Meanwhile optional 150Ah or 200Ah lithium battery.



### Lean Backrest

A semi-enclosed platform and lean backrest make the operator more comfortable and safer by reducing operator fatigue.



### Storage area

Storage areas for plastic wrap, documents, or writing boards, etc.

### Strong and durable body

Strong and durable body with a fixed platform, very suitable for high-intensity operation in logistic work. By traveling with the backside of the fork, one hand can ergonomically reach the grip, the other holds the tiller. For both left-handed and right-handed operation.



### Ergonomic design

Fixed or foldable platform with protective arms. The cushioned platforms ensure safety in all traveling conditions.



### Foldable platform

A foldable platform for higher flexibility in narrow spaces.

## PT 20/25P-C Fixed

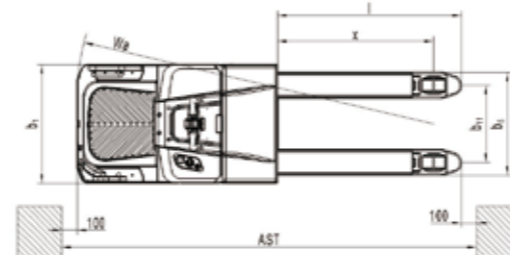
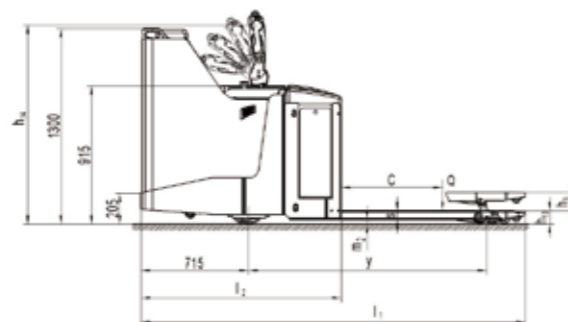

## Type sheet for industrial truck acc. to VDI2198

Type sheet for industrial truck acc. to VDI2198				
<b>Distinguishing mark</b>				
1.2	Manufacturer's type designation		PT20P-C (Foldable)	PT25P-C (Fixed)
1.3	Drive		Battery	
1.4	Operator type		Pedestrian/Stand	
1.5	Load capacity/Rated load	Q (t)	2.0	2.5
1.6	Load center distance	c (mm)	600	
1.8	Load distance, the centre of drive axle to fork	x (mm)	900 <sup>1)</sup>	970 <sup>1)</sup>
1.9	Wheelbase	y (mm)	1514 <sup>1)</sup>	1584 <sup>1)</sup>
<b>Weight</b>				
2.1	Service weight	kg	770	925
2.2	Axle loading, laden front/rear	kg	1030 / 1740	1325 / 2100
2.3	Axle loading, unladen front/rear	kg	590 / 180	725 / 200
<b>Tires, chassis</b>				
3.1	Tires		Polyurethane(PU)	
3.2	Tire size,front	Øxw (mm)	Ø 230×75	
3.3	Tire size,rear	Øxw (mm)	Ø 84×84	Ø 84×84
3.4	Additional wheels(dimensions)	Øxw (mm)	Ø 124×60	
3.5	Wheels,number front/rear(x=driven wheels)		1 x+2/4	1 x+2/4
3.6	Tread,front	b10 (mm)	520	
3.7	Tread,rear	b11 (mm)	367	512
<b>Dimensions</b>				
4.4	Lift	h3 (mm)	120	
4.9	Height of tiller in drive position min./max.	h14 (mm)	1100 / 1400	1095 / 1360
4.15	Height, lowered	h13 (mm)	85	
4.19	Overall length	l1 (mm)	1949	2549
4.20	Length to face of forks	l2 (mm)	799	1329
4.21	Overall width	b1 (mm)	790	
4.22	Fork dimensions	s/e/l (mm)	60 / 173 / 1150	60/ 173 / 1220
4.25	Width across forks	b5 (mm)	540 / 685	
4.32	Ground clearance, centre of wheelbase	m2 (mm)	25	
4.34	Aisle width for pallets 800 x1200 lengthways	Ast (mm)	2199	2767
4.35	Turning radius	Wa (mm)	1699 <sup>1)</sup> / 2667 <sup>1)</sup>	2317 <sup>1)</sup>
<b>Performance data</b>				
5.1	Travel speed,laden unladen	km/h	7.0 / 9.0	6.5 / 9.0
5.2	Lift speed,laden/unladen	m/s	0.025 / 0.035	0.035 / 0.060
5.3	Lowering speed,laden/unladen	m/s	0.030 / 0.030	0.050 / 0.050
5.8	Max. gradeability, laden/unladen	%	6 / 20	6 / 10
5.10	Service brake		Eletromagnetic	
<b>Electric-engine</b>				
6.1	Drive motor rating S2 60min	kW	1.6	
6.2	Lift motor rating at S3 10%	kW	0.8	2.2
6.3	Battery acc. to DIN 43531/35/36A,B,C,norm		B,2PzS	B,3PzS
6.4	Battery voltage,nominal capacity K5	V / Ah	24 / 180 <sup>2)</sup>	24/270 <sup>3)</sup>
6.5	Battery Weight	kg	170	235
6.6	Energy consumption acc. to VDI cycle	kWh/h	0.42	0.49
<b>Additional data</b>				
8.1	Type of drive control		AC speed Control	
8.4	Sound level at driver's ear acc. to EN 12053	dB(A)	<70	

1) when the load wheel is at lowered height :+65mm; 2) optional battery:210Ah, 270Ah, 315Ah; 3) optional battery:210Ah, 315Ah.

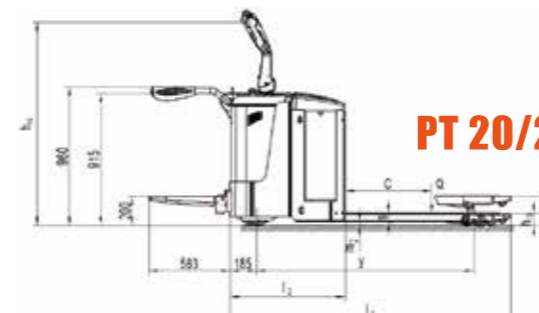

## PT 20/25P-C Foldable

